

# STEADICAM®

---

# STEADIMATE



Steadimate Operator's Manual

Rev. A

P/N: LIT-816790

Steadicam® and Steadimate™ are trademarks of The Tiffen Company.

Other trademarks are the property of their respective owners.

All specifications stated within this manual are subject to change without notice.



# Table of Contents

<b>A word from Garrett Brown</b>	2
<b>The Steadimate System</b>	4
Steadimate components	5
<b>Setting Up</b>	
Preparing the Steadimate	6
Installing the Steadimate	9
<b>Balancing</b>	
Upright or Inverted Mode?	10
Balancing Upright Mode	12
Balancing Inverted Mode	18
<b>The Vest</b>	
Vest components	26
Fitting the Vest	27
<b>The Arm</b>	
Arm components	28
Connecting the Arm and Vest	29
<b>Steadimate Operating</b>	
Lifting the system	30
Adjusting the Arm	31
Check your threads	32
Operating modes, tips and tricks	34
<b>Accessories</b>	38
<b>Maintenance and Cleaning</b>	39
<b>Contact Tiffen</b>	41

# A word from Garrett Brown

Hello and congratulations on your new **Steadimate™**. You're now equipped to 'fly' your motorized stabilizer on a Steadicam® arm and vest; so get set for a new, 'hybrid' experience.

If you're a longtime Steadicam operator who now has occasion to carry around a MōVI® or RONIN™, the Steadimate restores the weightless, fingertip moves you're used to: those graceful translations in space that are nearly impossible when your outstretched arms are heavily burdened.

If you're already a Movi/Ronin owner/operator, welcome to our world! You're in for a treat— a taste of what Steadicam aces have known and enjoyed for decades. Not just angular stability and classically smooth moves, but a chance to tirelessly 'operate' moving shots with improved precision and style.

Motorized gimbals have uncanny roll stability and anyone can pick one up and instantly move it around. But of course the stabilizer mechanism plus camera, lens, battery, etc. must be held out in front and moved through space by your heavily loaded arms—often for minute after minute—and the increasing fatigue can make your work look jerky and irregular as you pass foreground objects.

Steadimate floats your gimbal like a Steadicam sled, so the inherent inertia of the rig in space is fingertip detectable and your booming and traveling moves are Steadicam smooth. In addition, Steadimate is the only support mechanism that is neutrally balanced in two isolated axes for effortless pan and tilt (all others make the rig extremely bottom heavy and tough to tilt).

If you're operating solo, in what Movi calls 'Majestic' mode—without a second person controlling camera angle by joystick or wheels—the mushy operating initiated by the support handles can now be significantly improved. With Steadimate, you can tighten the tuning parameters so your pans and tilts are more instantaneous and precise, like the dynamic and responsive operation that Steadicam is known for.

So enjoy your new Steadimate™! It will not only relieve up to 25 lbs of outstretched burden, it will smooth the spatial component of moves as well as the angular bit that gimbals do so well.

...and don't forget to read The Steadicam Operator's Handbook by Jerry Holway and Laurie Hayball, with its vast amount of moving camera lore to help you accomplish what we all strive for—to make effective and memorable shots!

Best,



Steadicam® Inventor  
Philadelphia USA

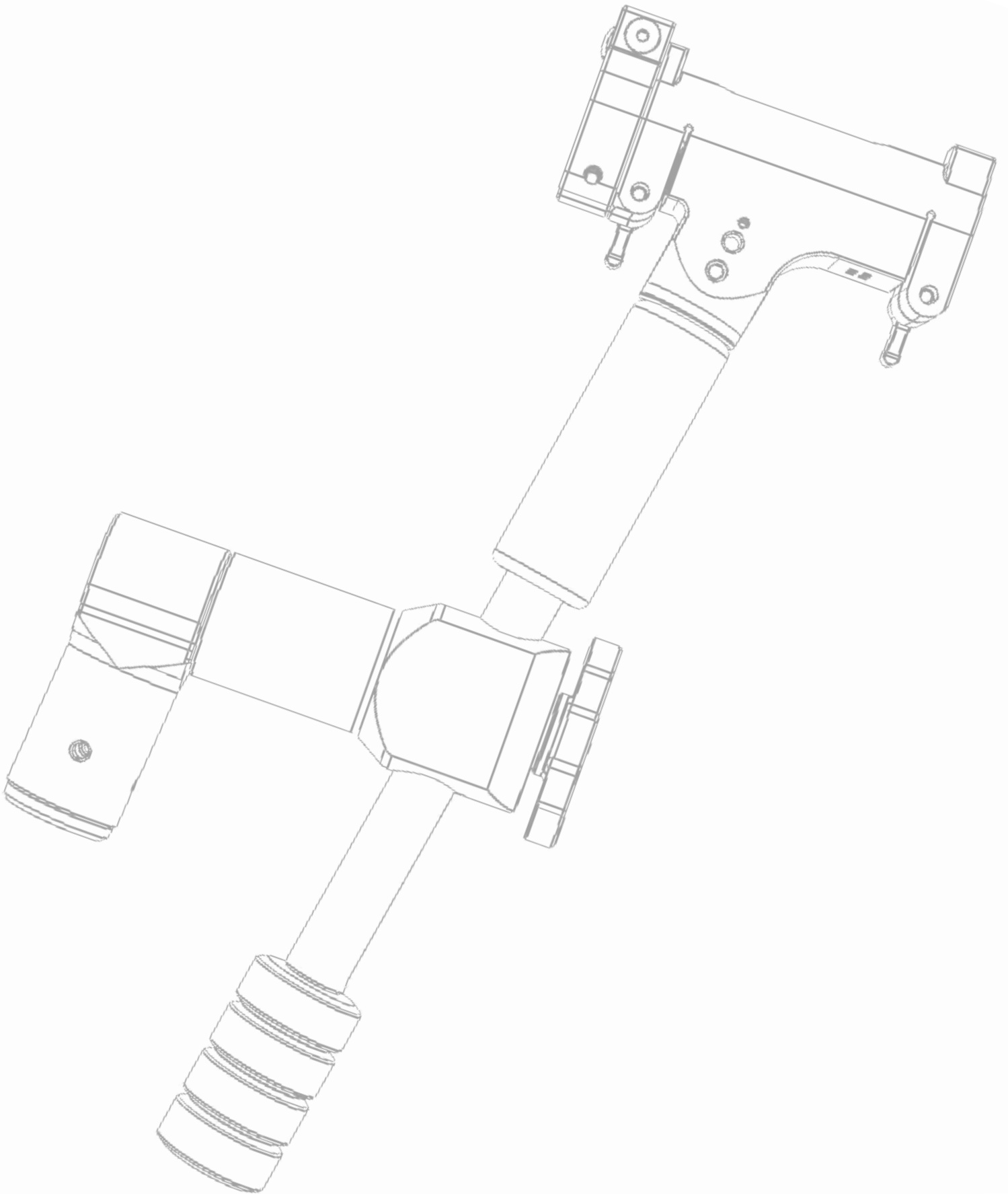

# The Steadimate System

**The Steadicam Steadimate** is the link between motorized gimbals and the traditional Steadicam Arm and Vest. Together, the Steadimate System provides additional stabilization and neutrally balanced tilting which result in smoother shots and less work for the operator.

## The Steadimate

Links The Arm to motorized gimbal  
Allows fingertip control

## The Vest

Adjustable to fit most operators  
Provides connection to the Arm



## Motorized Gimbal

DJI Ronin and Ronin-M  
Freefly Movi M5, M10 and M15

## The Arm

Supports the Steadimate System  
Isolates camera from operator

# Steadimate Components

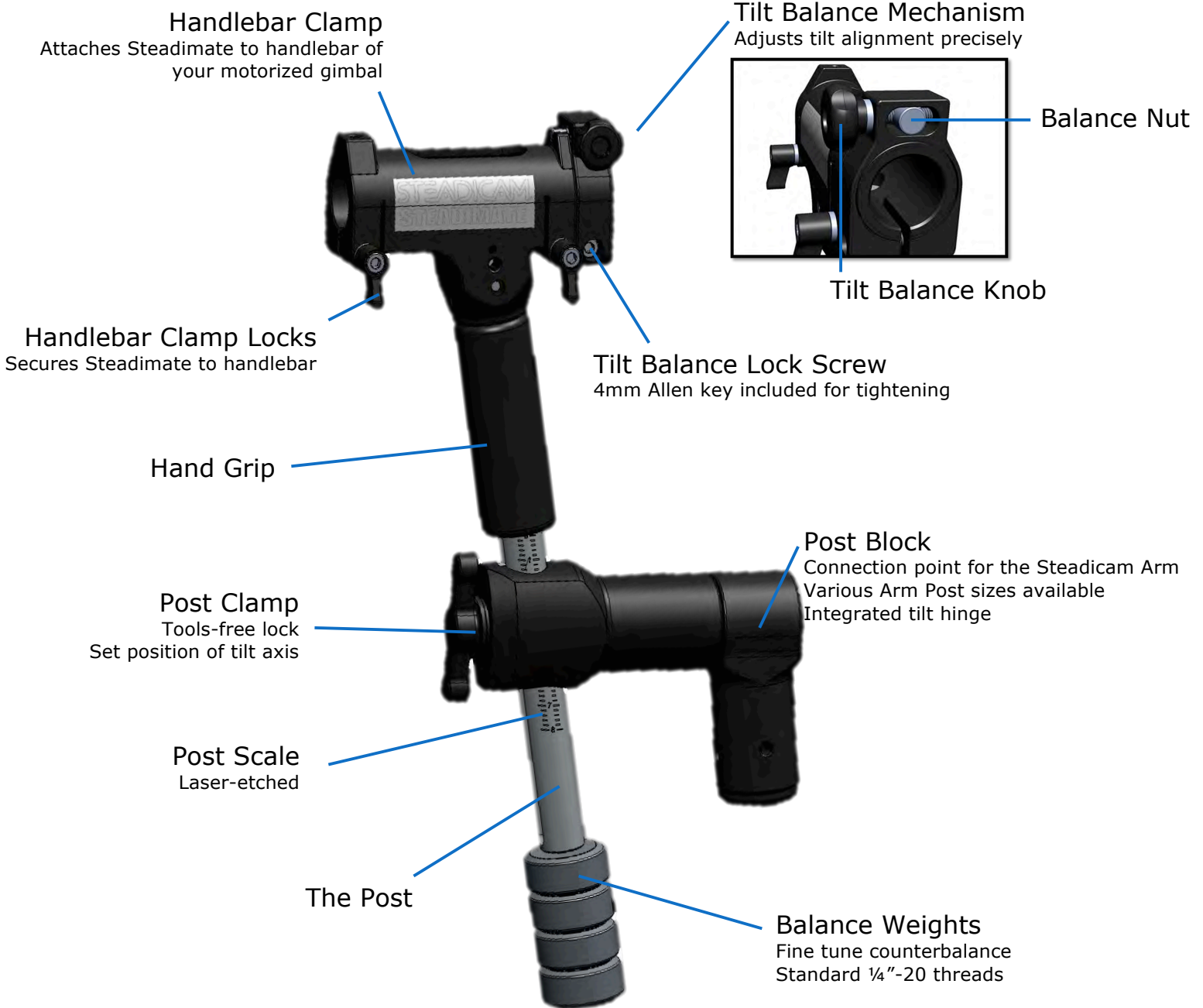

**Balance Pin**  
Install on top of tuning stand  
Verify system balance



**Clamp Inserts**  
25mm and 30mm inserts included





# Setting Up

## ***Prepare the Steadimate:***

Loosen the Handlebar Clamp Locks and Tilt Balance Lock Screw.

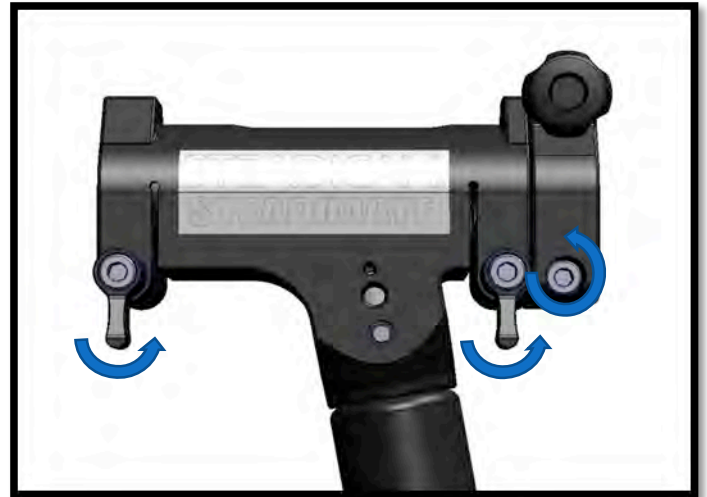

Center the Balance Nut within the Tilt Balance Mechanism by turning the Tilt Balance Knob. This gives us the maximum range of adjustability in either direction.

You may need to turn the Knob in either direction, depending on how the Steadimate was stored.

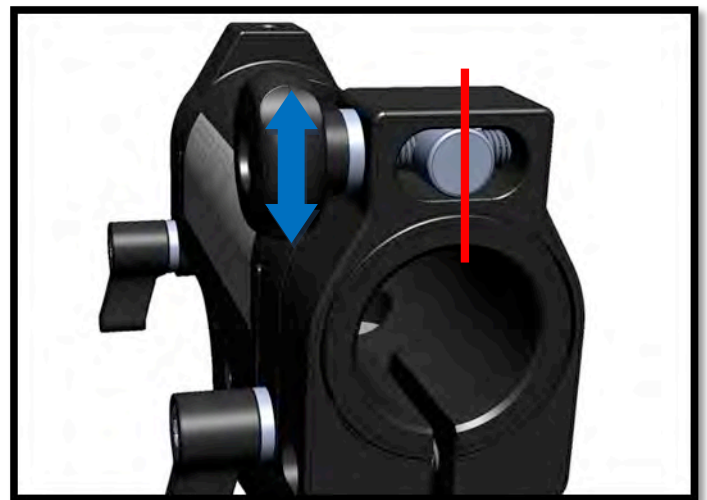

Take a moment to confirm that the Clamp Inserts are correctly sized for your motorized Gimbal. They're sized to fit either 25mm or 30mm handlebars.

With the Clamp Locks and Lock Screw loose, the Inserts simply snap in place.

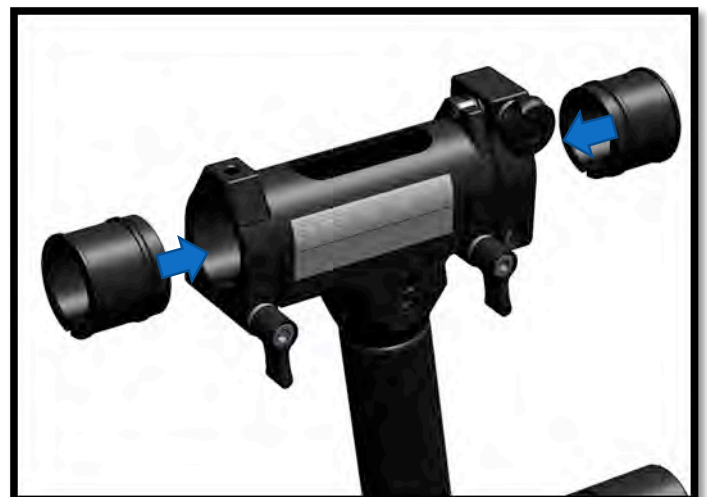

# Prepare the Steadimate



Install **two** Balance Weights at the bottom of the Steadimate Post.

The weights can be used for fine tuning the top-to-bottom or tilt CG of the Steadimate later. Great when adding or removing small accessories or swapping lenses.



Loosen the Post Clamp and slide it all the way up until it reaches the 0 position and then retighten the Post Clamp.

**Caution:** Only adjust the Post Block position while the system is on the tuning stand. Never loosen the Post Clamp while balancing or while the Steadimate is mounted on the Arm.

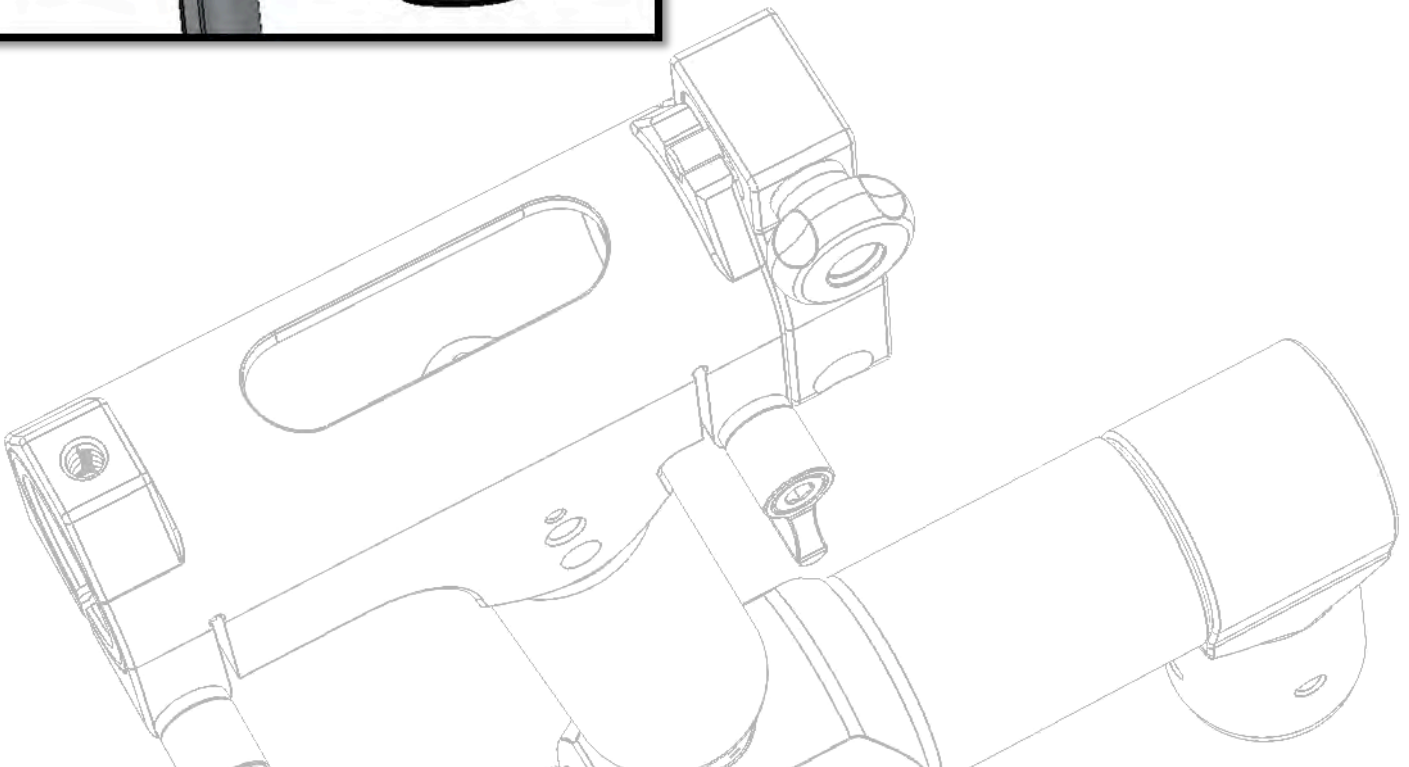

# Setting Up

## Is your motorized gimbal dialed in?

Proper setup of your motorized gimbal is **critical** to accurately balancing the Steadimate System. Refer to the manual from your motorized gimbal manufacturer for directions on proper tuning. Test handheld in single operator mode before going any further.

Add ALL required accessories and build a compact setup without loose components. We'll be balancing the entire Steadimate System, not just the camera.

Keep heavy accessories, like batteries, close to the Steadimate Handlebar clamp so the weight is well supported.

**Caution:** placing excessive weight far from the Steadimate Handlebar Clamp could over-stress the carbon fiber tube.

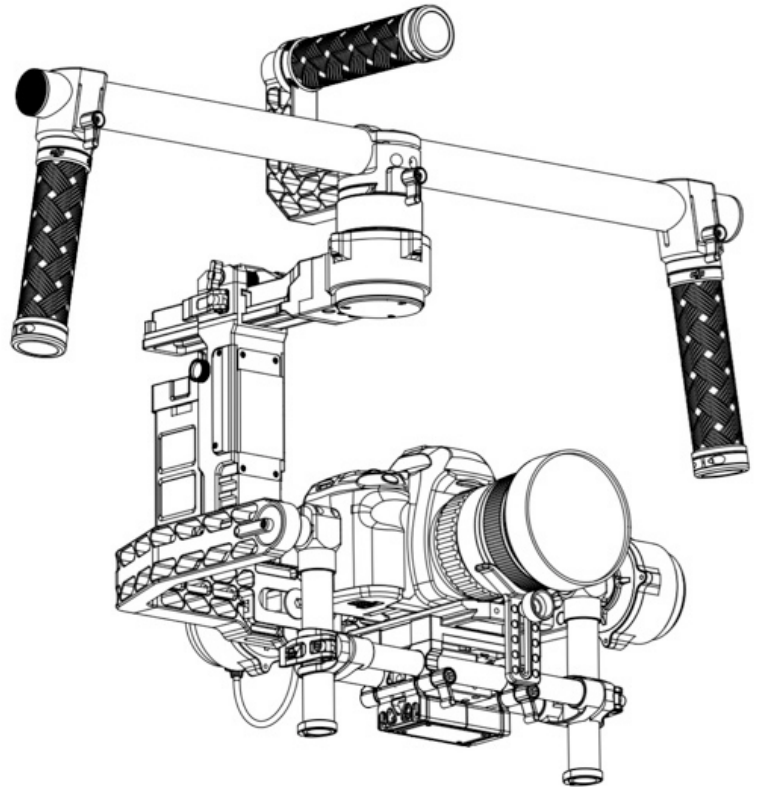

With the motorized gimbal resting on the tuning stand, remove the right side handle.

**Note:** If you prefer operating a Steadicam in Goofy Mode, you may choose to remove the left handle and install the Steadimate on the left side, instead.

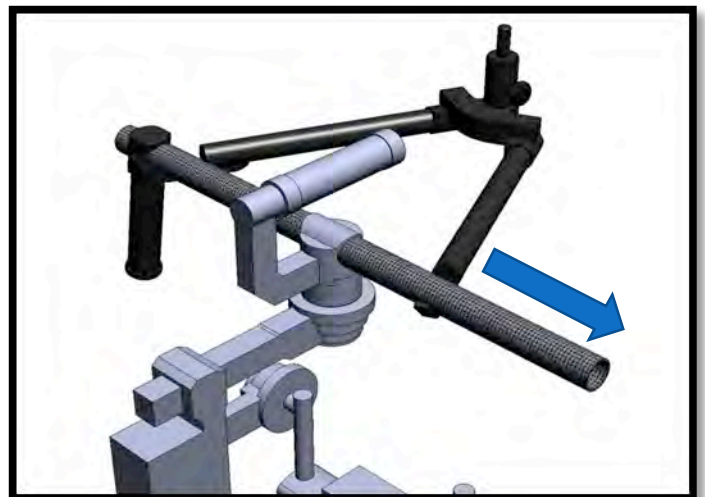

# Installing the Steadimate

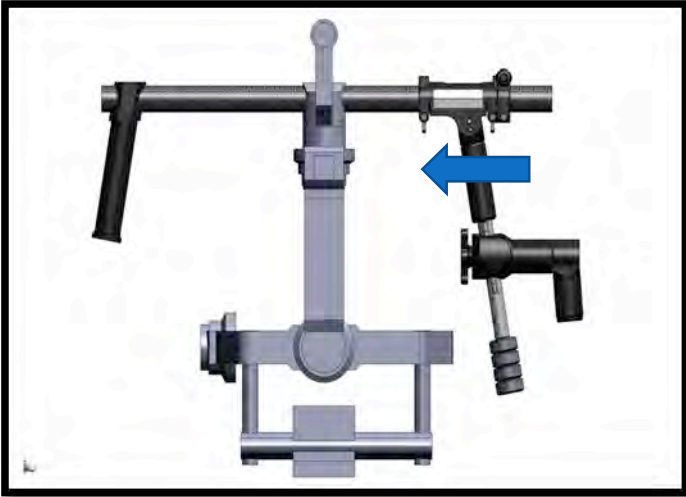

Slide the Steadimate onto the handlebar in place of the handle.

**Note:** For optimum performance and safer operation, keep the space between the Handlebar Clamp and the base of the pan motor as narrow as your build will allow.

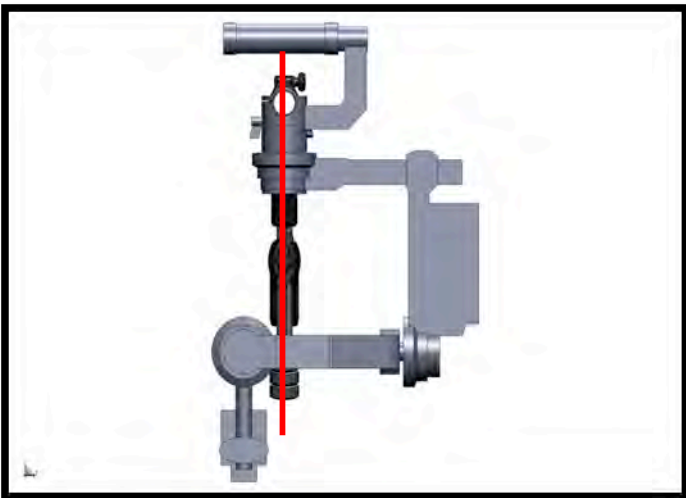

From the profile, visually align the Steadimate with the central axis of the pan motor. The Steadimate should be parallel to the vertical surfaces of the motorized gimbal when everything is centered.

Just get it close, we'll be using the Tilt Balance Adjuster to fine tune this in the Balancing section soon.

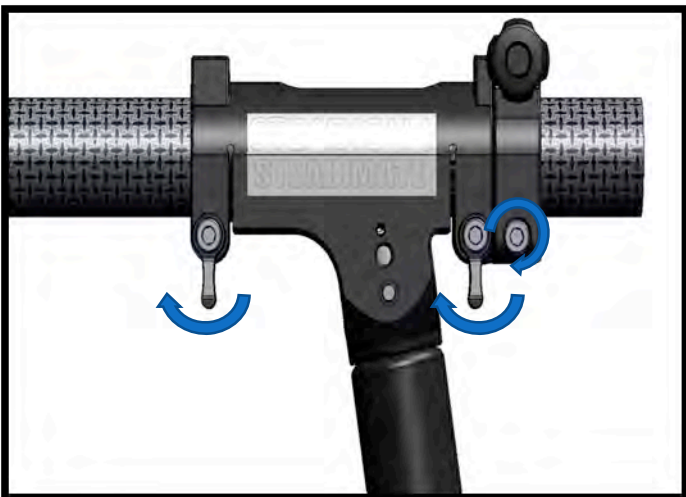

Tighten the Handlebar Clamp Locks by hand and securely tighten the Tilt Balance Lock Screw with the included 4mm Allen key.

# Balancing

**Balancing the Steadimate** system for the first time requires patience and attention to detail, just as you experience while setting up a motorized gimbal or traditional Steadicam for the first time. Read through the process and take your time.

**Note:** always balance the Steadimate with the motorized gimbal powered on and performing properly.

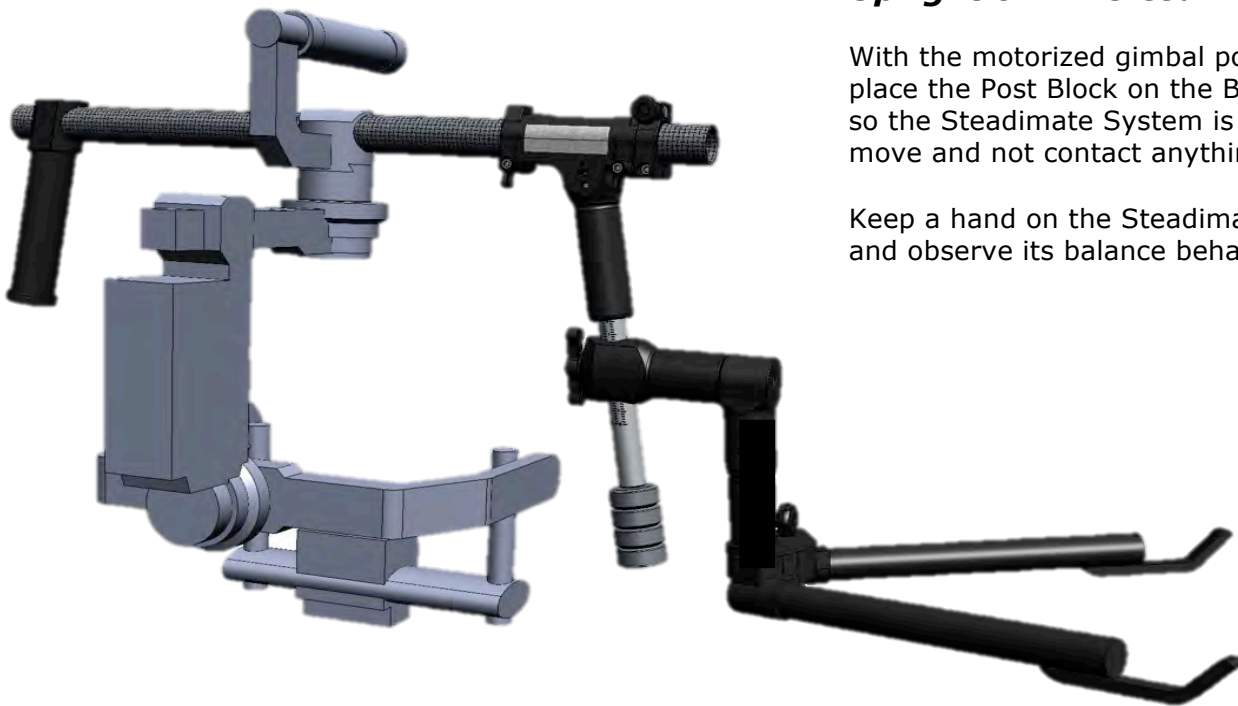

## ***Upright or Inverted Mode?***

With the motorized gimbal powered, place the Post Block on the Balance Pin so the Steadimate System is free to move and not contact anything.

Keep a hand on the Steadimate grip and observe its balance behavior.

Tilt the camera down and note the angle at which the Steadimate comes to rest. Then tilt up to see what the “balance window” angle is between the two resting points.

Also check to see if the Steadimate will stay parked vertical when the camera is exactly level.

## *Upright or Inverted?*

***If the Steadimate remains upright***, within 0-45° of vertical, you'll be balancing in Upright Mode. Most setups will be upright, just like operating a traditional motorized gimbal.

Flip to the next page to start Upright Mode Balancing.

***If the Steadimate is between 45° and horizontal***, confirm that the Post Clamp is set at number 0 and try adding 2 more Balance Weights. You may also remove or change your accessories to lighten the system.

If the changes you make achieve an upright Steadimate, then go on to the next page.

However, if the Steadimate is still more than 45° from vertical, you'll balance in Inverted Mode, starting on page 18.

***If the Steadimate is truly inverting***, where the Handlebar is below the Post Block, then you must balance in Inverted Mode.

This is most common when using heavy monitors with light weight motorized gimbals or when larger accessories are placed high on the top handlebar.

Jump to page 18 for Inverted Mode balancing.

# Balancing

**The Steadimate** has two adjustments which we use to balance the Steadimate system; the Tilt Balance Knob and the Post Clamp. The Tilt Balance adjustment enables us to precisely center the Steadimate with the motorized gimbal along the vertical axis. And by adjusting the location of the Post Clamp on the Post, we can place the center of gravity of the motorized gimbal **just** below the tilt axis of the Post Block. The goal is to make the system tilt and pan with fingertip control. Let's get started!

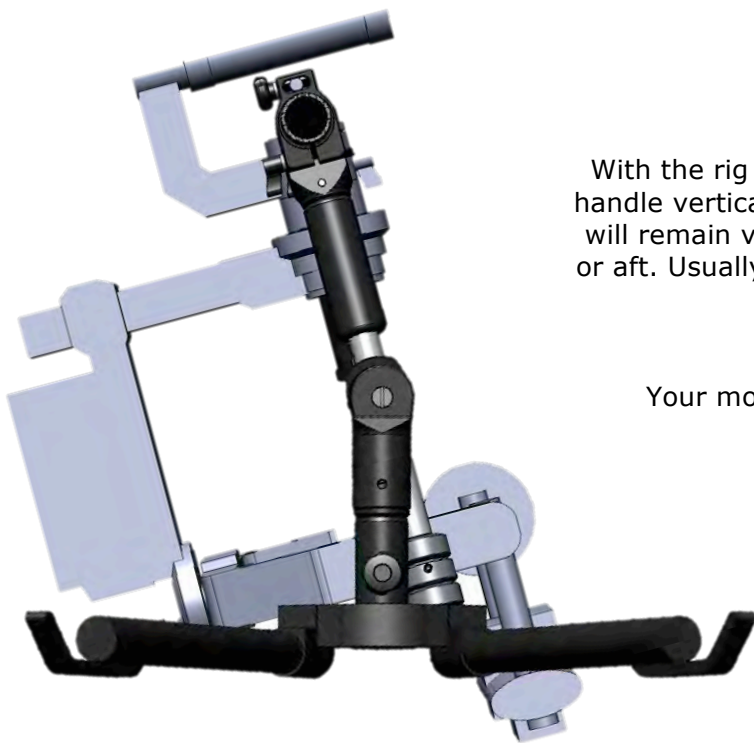

## **Center the Steadimate:**

With the rig on the Balance Pin, hold the Steadimate handle vertical and loosen your grip to test whether it will remain vertical on its own, or if it tries to tilt fore or aft. Usually, the Steadimate will tilt one way or the other.

Your motorized gimbal is still powered on, right?

While still on the Balance Pin, hold the Steadimate handle vertical and loosen the two Handlebar Clamp Locks.

**Note:** DO NOT loosen the Tilt Balance Lock Screw. It will act as a safety and works with the Tilt Balance Mechanism in the next step.

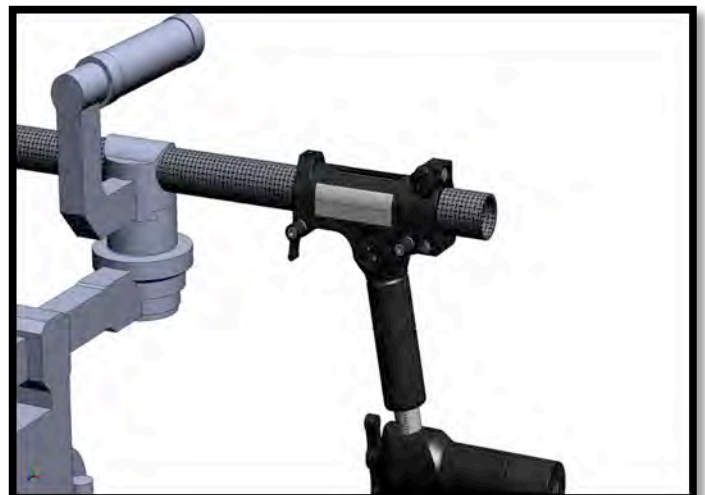

## Upright Mode: Centering



Turn the Tilt Balance Knob in either direction until the handle stays vertical. The direction you turn depends on which side the Steadimate is tilting.

You'll be able to feel the weight on the grip getting lighter when you turn the correct direction.

When you're close, try letting go completely to make sure the Steadimate remains perfectly vertical.

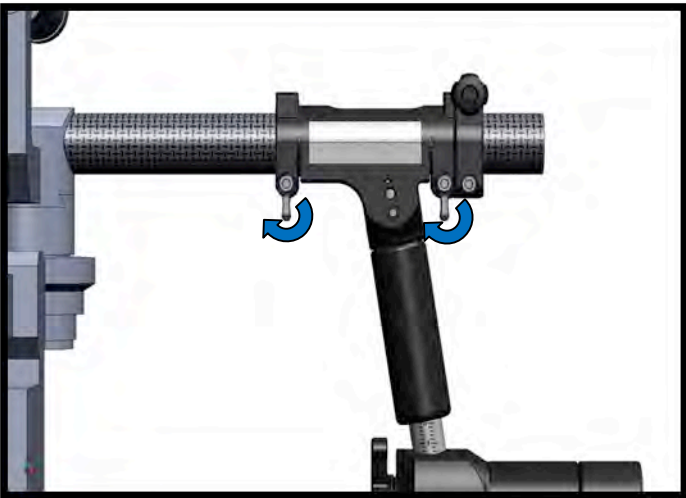

Now re-tighten the Clamp Locks.

**Note:** It should not be necessary to loosen the Tilt Balance Lock Screw unless your initial alignment was **way** off.

Always return the System to the tuning stand before loosening the Tilt Balance Lock Screw to realign the Steadimate on the handlebar.



# Balancing

**The next step** is where the magic happens. By moving the Post Block down the Post, we can adjust where the system's center of gravity is located relative to the Steadimate pivot. We use a simple method of guess and check to find that sweet spot. The lighter we can make the tilt axis, the less work you have to do tilting **and** the better isolated the camera will be from the operator's walking motion. If you're a Steadicam Operator, this is equivalent to setting your Drop Time.

## **Set the balance:**

Try tilting the Steadimate to aim the camera lens toward the sky. Does it tilt with fingertip control, or is it heavy?

**Note:** we'll be testing the balance of the system on the Balance Pin, but doing adjustments on the tuning stand. Then repeat until it's perfect.

If your Steadimate System is light to the touch and comes to rest within a 45° tilt window, congratulations! You're ready to rock the new Steadimate.

Most of the time, however, you'll need to adjust the Post Block height to find that perfect setup.

## Upright Mode: Balancing

If the tilt behavior is heavy, that means your system is too bottom heavy.

But instead of removing the weights, which you can use later for fine tuning, we'll move the pivot point down the Post.

Dock the Steadimate System on the tuning stand.

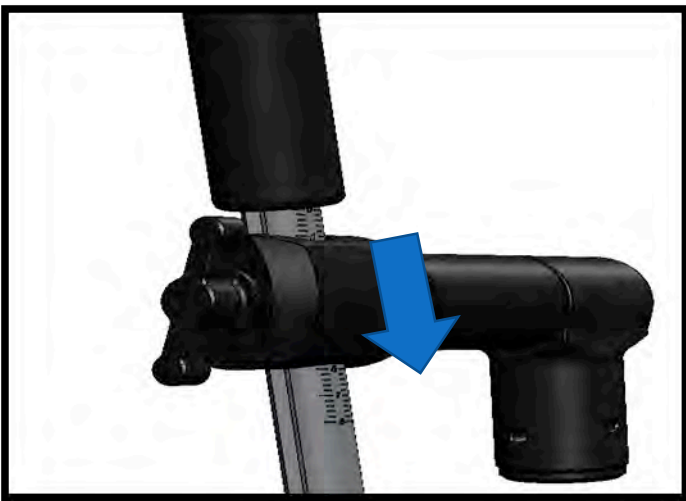

Loosen the Post Clamp and slide the Post Block one number down the Post scale and re-tighten the Post Clamp.

With more Steadimate experience, you'll gain a sense for how far to move the Post Clamp.

Until then, let's move one increment at a time.



Return the Steadimate to the Balance Pin and test tilt the system.

Find the resting points for tilting up and down and make sure they are within the 45° tilt window.

Repeat the last two steps until the tilting effort is very light. You're looking for fingertip control.

# Balancing

The closer your balance is to perfect, the more sensitive the Tilt Balance becomes.

Check that the system can remain vertical with a light touch. Is it tilting slightly again?



If necessary, go back and re-center the Steadimate using the Tilt Balance Knob as previously described in this manual.



If you lower the Post Clamp too far, you'll find the tilt window increasing beyond the ideal 45° included angle or going horizontal.

Simply revert back to the previous Post Scale setting that worked well.

## Upright Mode: Balancing



With the Post Block height set correctly, you can later add or remove weights when accessories, lens swaps or personal preference require small, quick changes to the CG of the system.



After repeating these steps a few times, you'll have found that ideal balance which reduces tilt and panning effort and also further isolates your camera.

Now skip on ahead to page 26 to learn about the Vest and Arm.

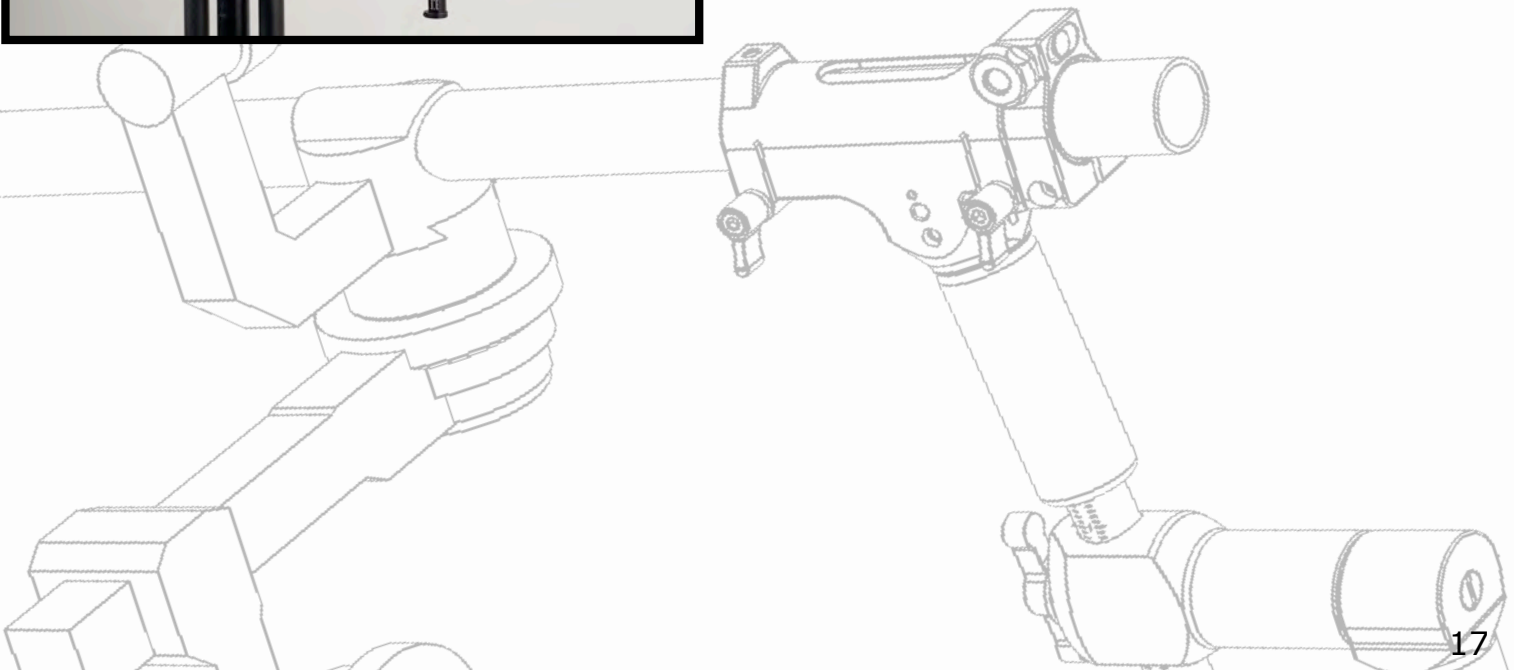

# Balancing

**The Steadimate** has two adjustments which we use to balance the Steadimate system: the Tilt Balance Knob and the Post Clamp. The Tilt Balance adjustment enables us to precisely center the Steadimate with the motorized gimbal along the vertical axis. And by adjusting the location of the Post Clamp on the Post, we can place the center of gravity of the motorized gimbal **just** below the tilt axis of the Post Block. The goal is to make the system tilt and pan with fingertip control. Let's get started!

## ***Prepare for Inverted Mode:***

Reverse the motorized gimbal mount at the handlebar so the camera will be pointing away from you.

Adjust the Post Clamp height to number 5 on the Post Scale, this will make the system more top heavy but we'll soon dial it in.

# *Inverted Mode: Centering*



Tilt your monitor for ease of viewing with the handlebar at the bottom.

## ***Center the Steadimate:***

Place the system on the Balance Pin and hold the Steadimate handle vertical. Slowly loosen your grip to test whether it will remain vertical on its own, or if it tries to tilt fore or aft. Usually, the Steadimate will tilt one way or the other.

Your motorized gimbal is powered on, right?

# Balancing

While still on the Balance Pin, hold the Steadimate handle vertical and loosen the two Handlebar Clamp Locks.

**Note:** DO NOT loosen the Tilt Balance Lock Screw. It will act as a safety and works with the Tilt Balance Mechanism in the next step.

Turn the Tilt Balance Knob one way or the other until the handle stays vertical.

You'll be able to feel the weight on the grip getting lighter until it is centered. Try letting go completely to make sure the Steadimate remains perfectly vertical.

Now re-tighten the Clamp Locks.

**Note:** It shouldn't be necessary to loosen the Tilt Balance Lock Screw unless your initial alignment was **way** off.

**Always** return the System to the tuning stand before loosening the Tilt Balance Lock Screw to realign the Steadimate on the handlebar.

# *Inverted Mode: Balancing*

**The next step** is where the magic happens. By moving the Post Block up or down the Post, we can adjust where the system's center of gravity is located relative to the Steadimate pivot. The good news is that we use a simple method of guess and check to find that sweet spot. The lighter we can make the tilt axis, the less work you have to do tilting **and** the better isolated the camera will be from the operator's walking motion. If you're a Steadicam operator, this is equivalent to setting your Drop Time.

## ***Set the balance:***

Try tilting the Steadimate to aim the camera lens toward the sky. Does it tilt with fingertip control, or is it heavy?

This time, we'll be testing the balance of the system on the Balance Pin, but doing adjustments on the tuning stand. Then repeat until it's perfect.

If your System is light to the touch and comes to rest within a 45° tilt window, congratulations! You're ready to rock the new Steadimate.

Most of the time, however, you'll need to adjust the Post Block height to find that perfect setup.



# Balancing

If the tilt behavior is heavy, that means your system is **too** bottom heavy.

But instead of removing the weights, which you can use later for fine tuning, we'll move the pivot point down the Post.

Dock the Steadimate System on the tuning stand.

Loosen the Post Clamp and slide the Post Block one number down the Post scale and re-tighten the Post Clamp.

With more Steadimate experience, you'll gain a sense for how far to move the Post Clamp.

Until then, let's move one increment at a time.

Return the Steadimate to the Balance Pin and test tilt the system.

Find the resting points for tilting up and down and make sure they are within the 45° tilt window.

Repeat the last two steps until the tilting effort is very light. You're looking for fingertip control.

## ***Inverted Mode: Balancing***

The closer your balance is to perfect, the more sensitive the Tilt Balance becomes.

Check that the system can remain vertical with a light touch. Is it tilting slightly again?

If necessary, go back and re-center the Steadimate using the Tilt Balance Knob as previously described in this manual.

If you lower the Post Clamp too far, you'll find the tilt window increases beyond 45° included angle.

Simply revert back to the previous Post Scale setting that worked well.

# Balancing



With the Post Block height set correctly, you can later add or remove weights when accessories, lens swaps or personal preference require small, quick changes to the CG of the system.



After repeating these steps a few times, you'll have found that ideal balance which reduces tilt and panning effort and also further isolates your camera.

Now we'll learn all about the Vest and Arm.

## *Inverted Mode: Balancing*

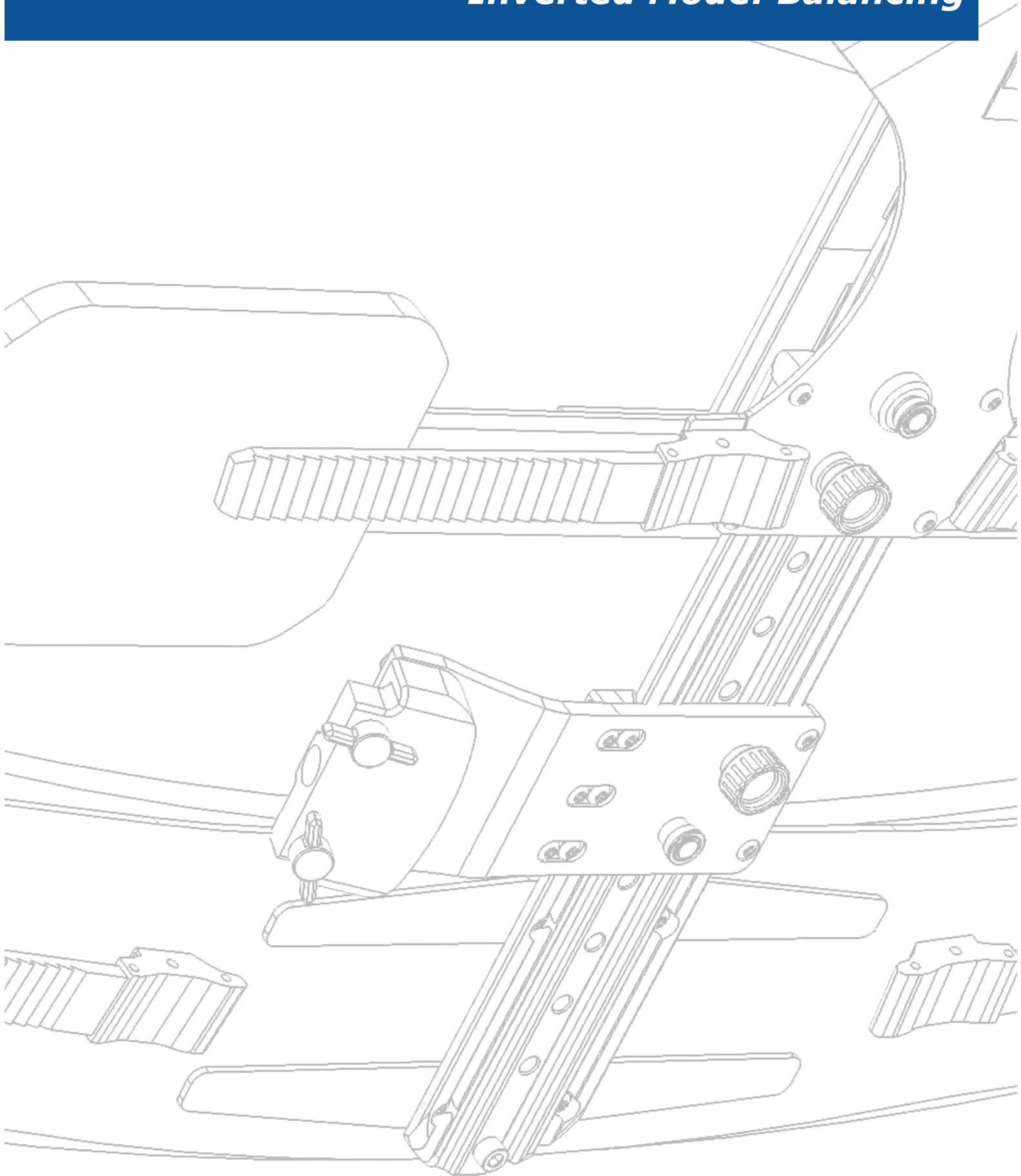

# The Steadicam Vest

**The Steadicam Vest** is the major connection between your body and the Steadimate System. It's adjustable to fit most body types via Velcro straps and micro-adjustable buckles. Just like setting up the Steadimate, taking your time to properly fit the vest will ensure you get the highest performance and most comfort out of the system.

## General Components of a Steadicam Vest:



**Note:** If you already have a Steadicam kit, you can use your Vest and Arm with the Steadimate. Just get the correct Insert for the Post Block to match your Arm Post and you're ready!

# Fitting the Vest

## Proper Vest fit:

The length of the Vest should place the waist low over the hip bones yet still allow your legs to lift for climbing stairs.

The Center Spar should stay centered on your torso and not slip to either side.

The Shoulder Connectors should not ride high and the Shoulder Pads should rest on your shoulders.

The fit should be very snug but not straightjacket tight.

The Socket Block should move with you and not shift under load.

When adjusting Velcro straps, keep them symmetrical across the back and waist.

It can be helpful to have a friend assist you when fitting the vest for the first time. If you don't have someone to assist you, a full length mirror also works.



- Open all buckles on the left side of the vest and slip the vest on.
- Close the Shoulder Connector.
- Leave all other Buckles open until the end of fitting.
- Connect the chest straps and center the Chest Plate on your chest.
- Pull down on the Chest Plate to seat the shoulder pads on your shoulders.
- Adjust the overall Vest length so the Hip Pads are centered over your hips.
- Be sure the Hip Straps are horizontal on the Pads and tighten them evenly.
- Pull down on the Vest to ensure it is centered and covering your hips.
- Close the Buckles on the Hip and Chest Straps.
- The Vest should be snug but not uncomfortable.
- Look at the the good fit of the Vest in these photos. It's important that the Shoulder Pads contact the shoulders and the connectors are not too high.

**Note:** A few operators may want to add or remove padding, shorten or extend straps in order to get a perfect fit to their body. Customizing your vest may make you much more comfortable.

# The Steadicam Arm

**The Steadicam Arm** supports the weight of the Steadimate System while helping isolate the camera from the operator's movements and facilitates booming up and down. The lifting strength of the arm is adjustable to accommodate a wide range in payload. It also incorporates Side-to-Side Adjustment Wheels which help align the lifting axis to your body.

## General components of a Steadicam Arm:

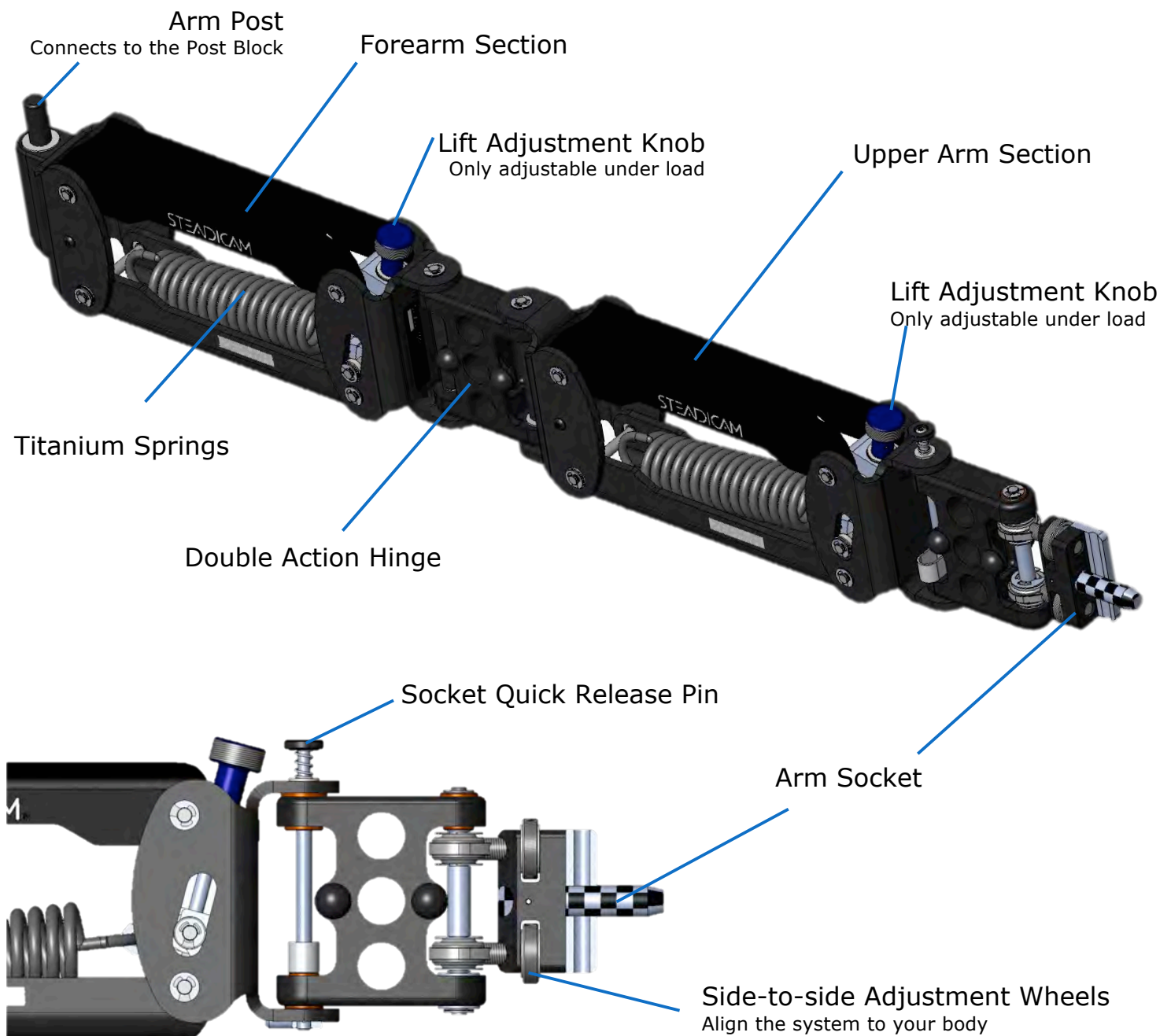

# Connecting the Arm and Vest

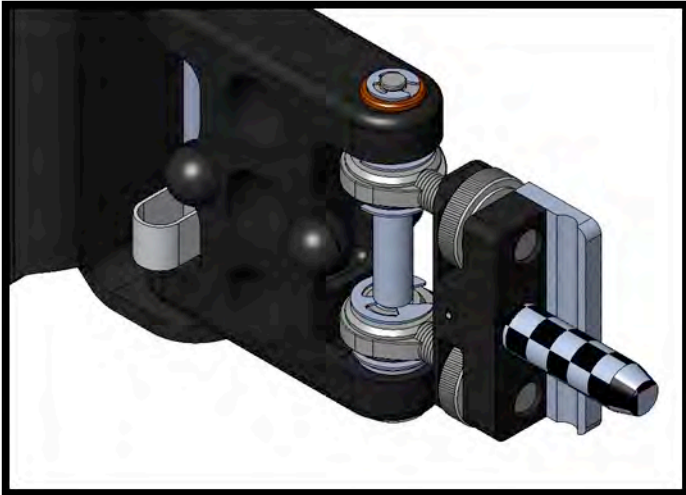

## **Set the "Threads" to start:**

The top Adjustment Wheel should be turned all the way in, so no threads are showing and then back out 2 full turns.

The bottom Adjustment Wheel should be turned all the way in until it stops.

This will put the lifting axis in line for most operators and probably won't change more than 1/2 turn one way or the other for you.



Insert the Arm Socket into the Socket Block of the Vest. Then use the Thumbscrew Bolts to secure the connection.

**Important:** Always keep a hand on the free end of the arm or you risk hitting someone, something, or even yourself in the face!



If you're slender, the top Thumbscrew will be most of the way in. If you're more generously proportioned, the top Thumbscrew will be some turns out from there.

Always dial the top Thumbscrew to your preferred setting and then snug up the lower screw.

The Thumbscrews do not need to be especially tight, but snug enough to keep the arm secure in the Socket Block.



# Steadimate Operating 101

**We're almost there!** Let's learn to pick up the rig and get the arm adjusted for your body and the weight of the Steadimate System. You'll have to be wearing the weight of the system to make these adjustments.



With the tuning stand raised so the Handlebar of your motorized gimbal is roughly at your chin level, bow to the Steadimate and place the Arm Post into the receiver on the Post Block.

Keep your knees straight and bend at the hips.



Take a step towards the Steadimate and stand up straight. Let the arm take the weight and compress.

You can now lift the Steadimate System clear of the tuning stand and step back.

Docking again is the exact opposite; rest the handlebar on the tuning stand and bow to release the Arm Post before stepping back.



## **Adjust the Lift:**

**Important:** The Lift adjustment knobs can only be adjusted when the arm segments are slightly above horizontal. Do not force the knobs when the arm is unloaded or boomed too far up or down. At the correct angle, the knobs turn very easily.

If the arm floats too high or too low for your payload, it will be necessary to lift or lower it to find that sweet spot to make adjustments.



Ideally, both arm sections will come to rest slightly above horizontal, by about 5-10°.

With the arm in the middle of its boom range, does it rise or fall?

Turn the Forearm Lift Adjustment Knob clockwise to add lifting strength or counterclockwise to reduce the lifting strength.

Make small adjustments until the Forearm segment is lifting the Steadimate System just above horizontal.



Repeat the adjustment on the Upper Arm section in the same way. Look to get the Upper Arm to follow the Forearm section as you boom up and down.

**Caution:** Never let your hand or fingers reach into the open areas of the arm near the springs. If the arm rises while anything is in this area, it may be pinched and injured.

# Steadimate Operating 101

## **Testing your threads:**

Stand up straight and look straight ahead.

Is the Steadimate System comfortably staying in one place in front of you?

**Note:** it's helpful to remember your thread settings so you can return to the ideal settings quickly next time.



**If the rig tends to move straight away from you;** loosen the bottom Thumbscrew and tighten the top Thumbscrew until the rig is neutral. Then re-tighten the bottom Thumbscrew.

**If the rig tends to move towards you;** loosen the top Thumbscrew until the rig behaves and then tighten the bottom Thumbscrew.

**Remember:** both Thumbscrews must be snug before you get to work.

Typically, your side-to-side adjustment won't need to be changed, but if the System does move to one side, you can correct it here.

Remove the arm and add or subtract a half turn of the **top** Adjustment Wheel at a time and retest.

Most operators leave the bottom Adjustment Wheel at 0 turns and the top Adjustment Wheel set 1.5-2.5 turns out from 0.

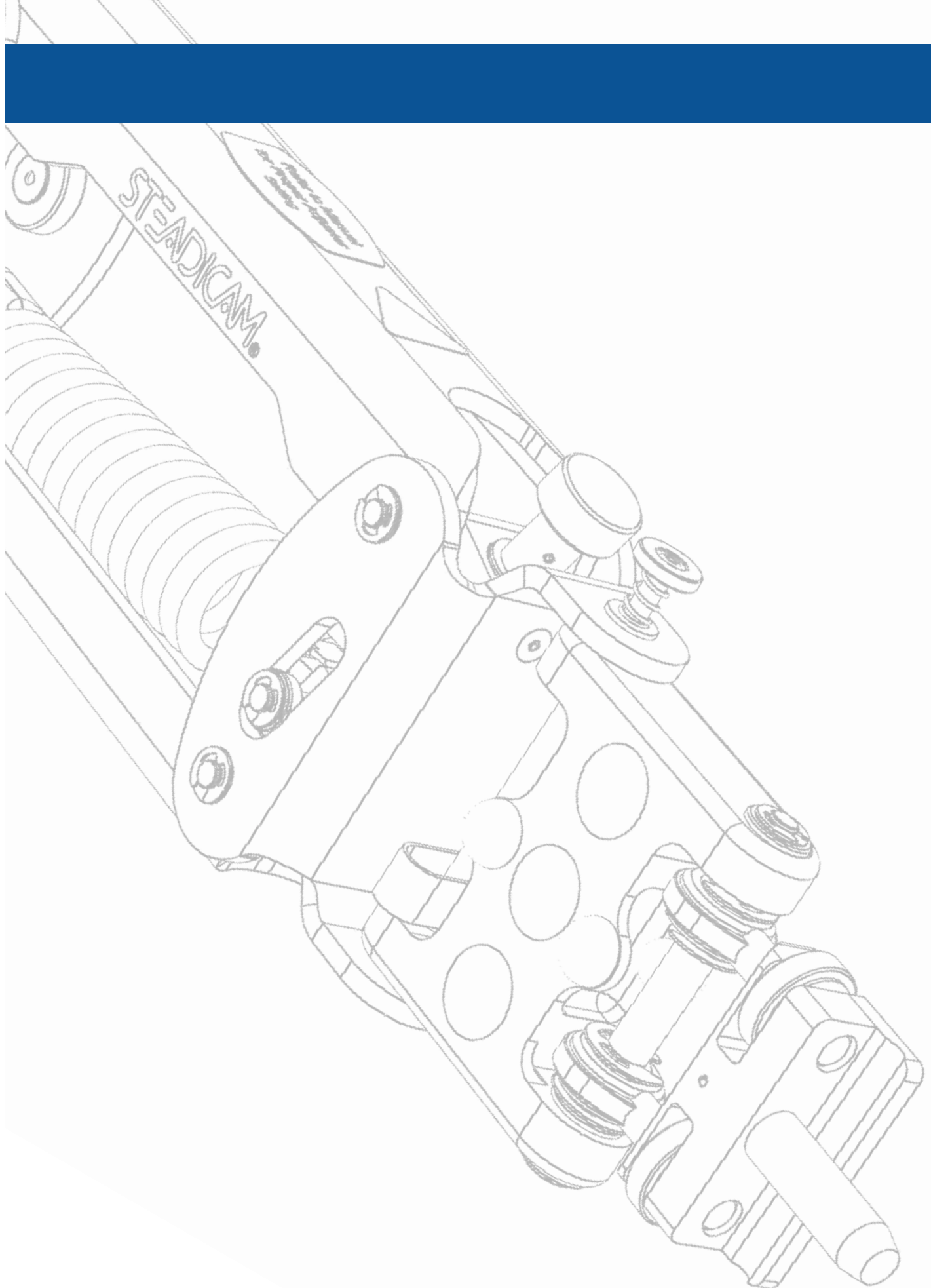

# Steadimate Operating

**The Steadimate System** is now capable of helping you create dynamic, endless, moving shots all day long. It is truly a hybrid machine with its own unique strengths. And yet, you can still quickly take advantage of handheld opportunities when needed and then go right back to Steadimate mode with the Arm and Vest without losing a beat. Handoffs are even possible!

The balance of the Steadimate allows very light control input for tilt and panning moves. This fingertip control allows increased accuracy and repeatability of shots. More importantly, you can truly 'fly' the camera now, letting the inertia of the rig increase the spacial stabilization.



Before we explore Steadimate Operating, remember that you're still able to pick up the motorized gimbal by hand for traditional operating. No need to replace the original hand grip or rebalance the Steadimate.

This allows you to decide the best mode **for each and every shot** with no setup changes.

When operating as Steadimate, stand up straight whenever possible and let the Arm and Vest do the work.

Your static posture should place most of your weight on one foot so you're always ready to move in any direction.





Similar to traditional Steadicam operating, we start and finish every move with the arm.

At the start of a shot, before taking a step, move the Steadimate System in the direction of travel and then follow along on foot.

At the completion of the shot, stop walking first and bring the camera to rest with only your arm movement.

And if you don't have to step, don't step!



When walking backwards for a leading shot, use a spotter to keep you safe.

Your spotter can place a hand on the back of your vest to guide you clear of obstacles or even catch you if you misstep.

Learn to look away from the monitor briefly while walking back; you can maintain framing even when you're not looking!



We can extend our range of movement by sitting down or kneeling.

Or by stepping up onto objects like apple boxes, curbs or benches.

It's also possible to kneel on a western dolly to get very low, but be careful.

# Steadimate Operating

If you're walking through a skinny door, here's a trick:

Go one handed while approaching the door and use the free hand to force the center hinge of the Arm inward, making you narrow.

**Important:** DO NOT to place your fingers inside the arm mechanism or it might bite!



It is possible to do handoffs with an operating partner for trick shots like going through windows or over tables.

Slide your hand down from the Steadimate Hand Grip onto the top of the arm, press down and bow slightly.



Your partner is able to lift the Post Block off the Arm and take over. The reverse also works; picking up the rig from your handheld buddy. Practice these tricks off set and get in sync with your partner.

**Be very careful** where you place your fingers so they don't get pinched when the arm rises.





You may wish to operate with the Steadimate inverted even with a light system. You may find it more comfortable for certain shots, or you wish to raise the lens a little.

Reverse the motorized gimbal orientation on the handlebar so the camera faces forward.

Adjust the Post Block height so the Steadimate tilts with that familiar fingertip control.

For more information, refer to the Inverted Mode Balance section starting on page 18.

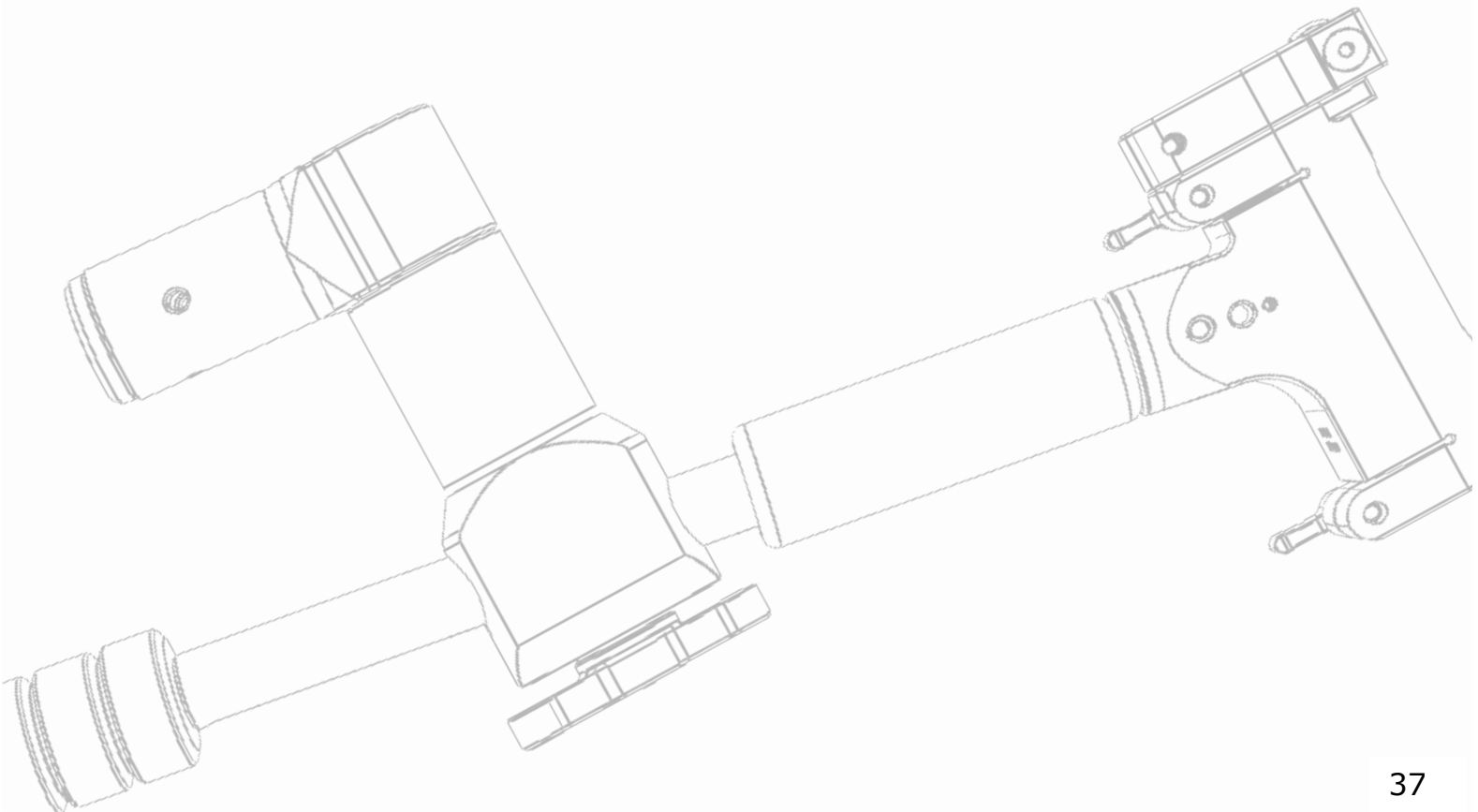



# Steadimate Accessories

Here are a few Tiffen accessories you might want to add to your Steadimate System. Check our website at [www.Steadicam.com](http://www.Steadicam.com) for the latest innovations in camera stabilization.

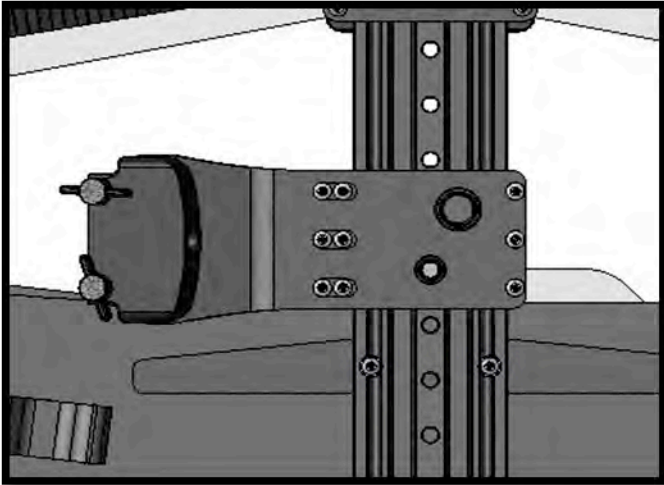

**Flipped Bridge Plate**  
Allows the arm to cross your body  
*Narrow operating for doorways*



**Arm Post Inserts**  
Available For  $\frac{1}{2}$ " and  $\frac{5}{8}$ " and  $\frac{3}{4}$ " posts  
*Use the Steadimate with various brands and models of arms*

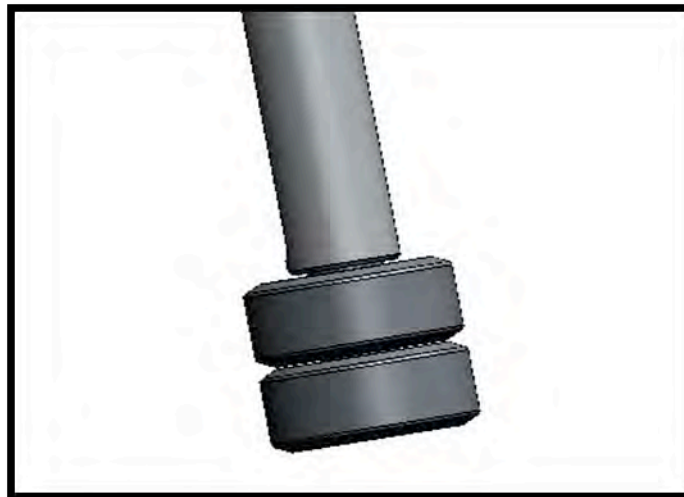

**Balance Weights**  
Additional  $\frac{1}{4}$  lb weights

# Maintenance and Cleaning



## **The Steadimate**

A microfiber cloth misted with window cleaner can be used to remove grime and fingerprints. Do not use harsh chemicals.

A touch of light grease on threads can help them work smoother, but **DO NOT** attempt to lubricate the bearings in the Post Block.

Check the movement and condition of all parts between shoots to ensure everything is operating properly.

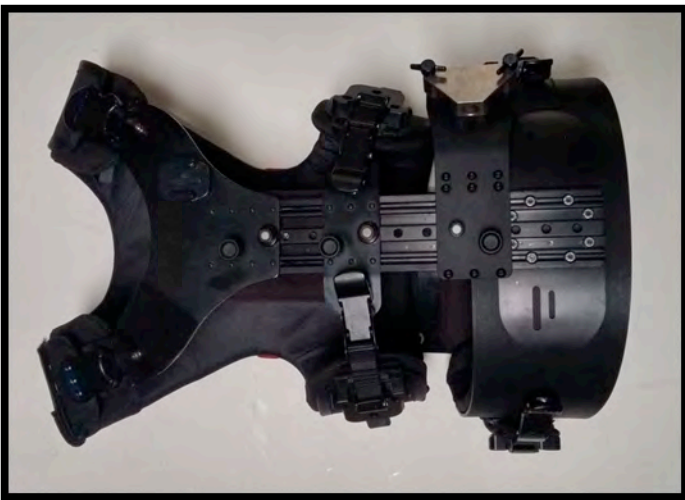

## **The Vest**

Use a lightly dampened microfiber cloth to wipe dirt and grime off the hard parts of the vest.

Since the vest pads are removable, they can be hand washed and air dried. Not a bad idea after a few shoots in warm weather.

Check the mechanical pieces occasionally for wear, damage and fasteners that may have come loose.

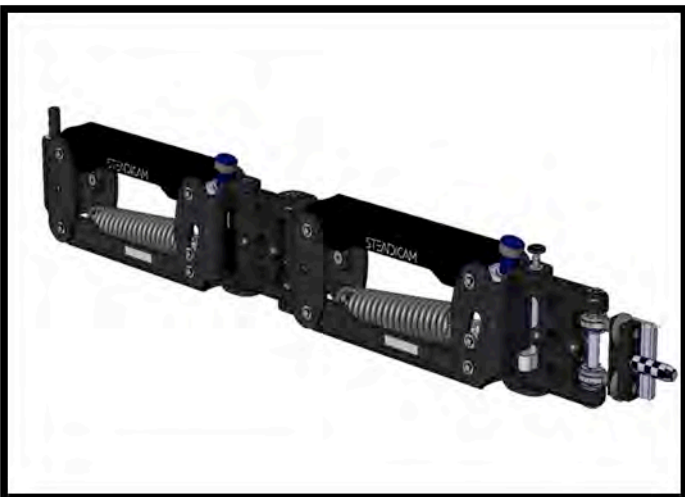

## **The Arm**

Like the rest of the system, cleaning the arm is just a matter of wiping it with a microfiber cloth sprayed with window cleaner.

Visually check the arm for any damage, especially if it's experienced rough use.

DO NOT lubricate any part of the arm! It should be silent, free moving and consistent. If for any reason it's not, contact Tiffen for service.



## Contact Tiffen

### **The Tiffen Company**

**Address:** 90 Oser Avenue  
Hauppauge, NY 11788

**Phone:** 631-273-2500 \* 1-800-645-2522

### **Tiffen-Steadicam**

**Address:** 2815 Winona Avenue  
Burbank, CA 91504

**Phone:** 818-843-4600 **ext.** 7910 \* 1-800-593-3331

### **Tiffen International Ltd.**

**Address:** Eastside Complex - Pinewood Studios  
Pinewood Road  
Iver Heath SLO ONH  
United Kingdom

**Tel:** (44) 870 1001220

**Fax:** (44) 1869 321766

**email:** [info@tiffen.com](mailto:info@tiffen.com)

**[www.tiffen.com](http://www.tiffen.com)**

Tiffen International Ltd.  
Pinewood Studios  
Pinewood Road  
Iver Heath  
SLO ONH  
United Kingdom  
Tel: (44) 1753 783 960  
Email: [info@tiffen.com](mailto:info@tiffen.com)