

WAVE¹

Manual

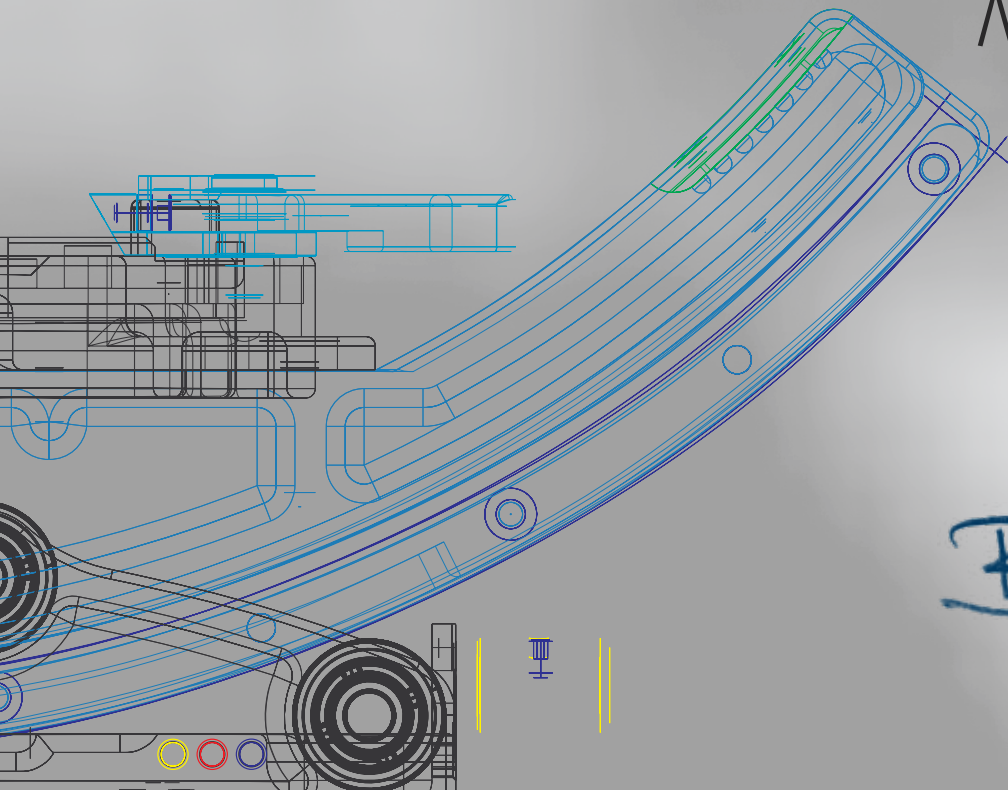

betz-tools.com

The camera weight has always be adjusted in the radius of the center of gravity! (A)

Use Motors and Accessories to keep the Cameras rotating point Balanced to the optical axis

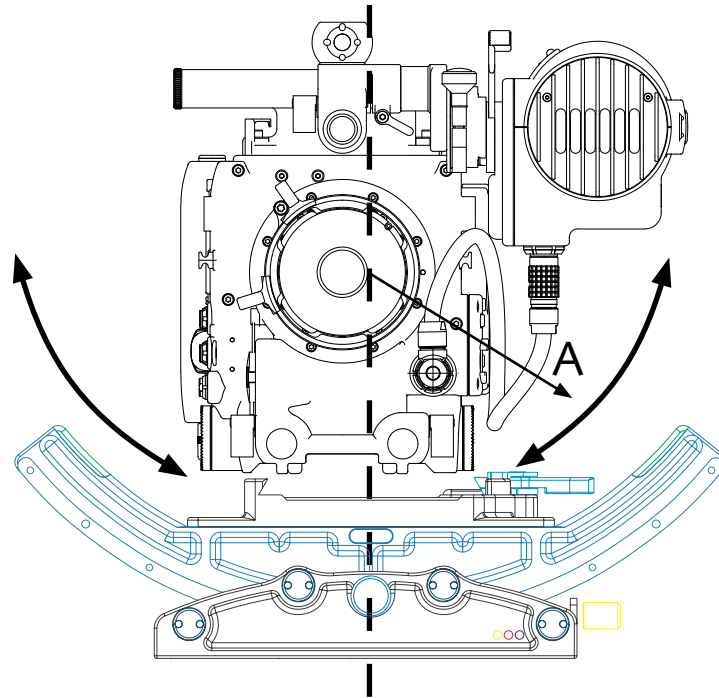

In upside down mode never mount the camera on its handle!
This way of mounting will cause vibration. It is easy to flip the picture.

Camera and Wave mounting

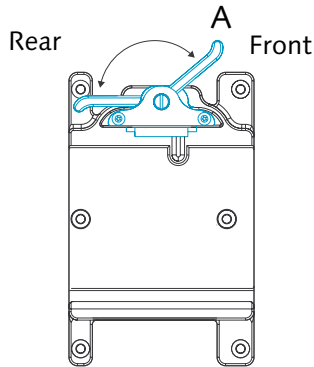

Attach camera with mounted dovetail plate and make sure that all parts and the camera itself is fixed perfect and nothing can vibrate.

Make sure that the clamp lever on the stage faces to the rear (A) so that the clamping is open. After the camera snaps in, the clamp lever snaps to the front. The camera is now protected against sliding out.

Never close or operate the closer mechanism by force.

By pulling the clamp lever towards stage rear, approximate fore/aft balance can now be achieved by sliding of the camera in the stage.

The clamping lever should lock the camera even before being pressed to the final stop!

In case the camera can still be moved even though the lever is pressed until stop cause of different tolerances of the dovetail plates a spacer of approx. 0,1 mm (0.004") has to be put under the compensation track under the cover plate. (see maintenance)

To remove the camera, the dovetail clamp must be opened by pulling the clamp lever fully to stage rear.

Mounting the Wave onto a device:

Bottom side you will find two 3/8" threads and also four M5 threads.

Mounting Template

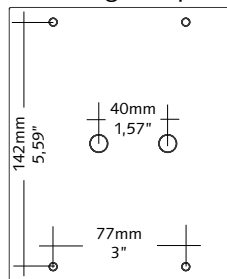

Frontside and Basics to Start

Wave must be in a leveled position before connecting to power.
Power LED flashes keep Wave in position "Zero" Initialisation runs for about 5 sec.

Lock Pin must be engaged before turning into "upside down" mode.

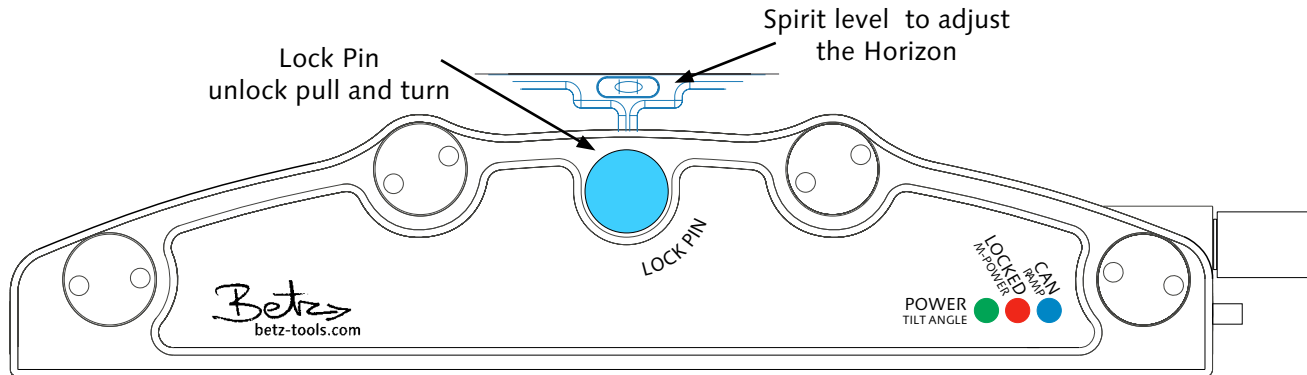

- Power LED: On = Ready to go
Flashing = "Zero" Initialisation ca. 5 sec.
- Locked LED: On = Lock Pin engaged
Flashing = Fault Restart
- CAN LED: On = External CAN Device is connected.

Control Panel

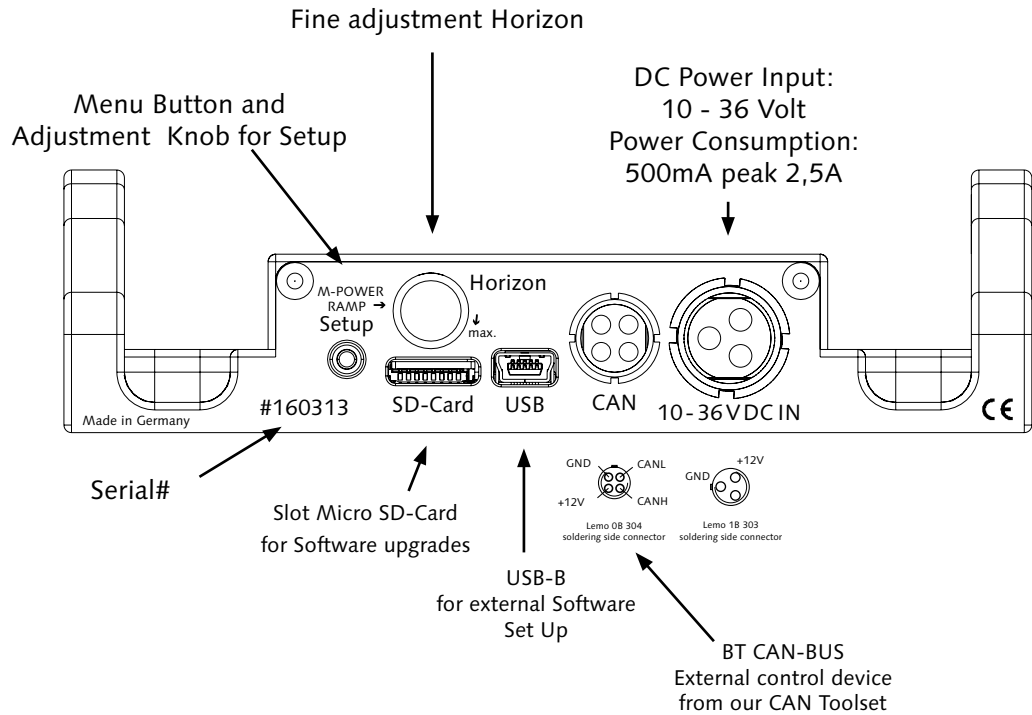

SET UP Tilt Angle

From a certain point of the Tilt-Angle it doesn't make sense to stabilize the horizon. For this reason the stabilization of the horizon will be frozen in a defined Tilt angle. The Tilt angle can be adjusted individually as follows.

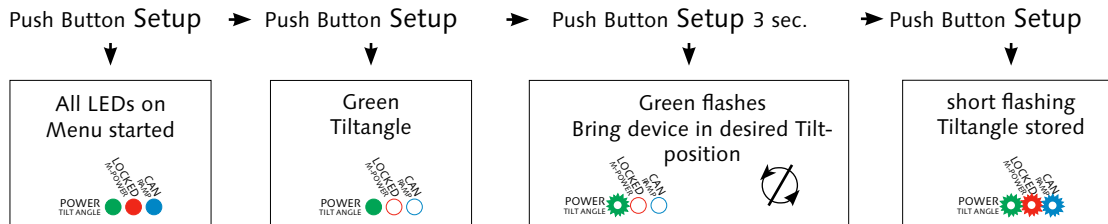
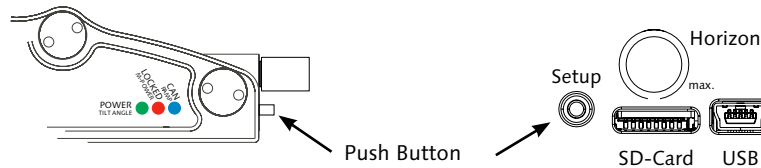

SET UP Motor Power

The basic setting for the motor power is fine for a wide range of camera weights.
If the power is adjusted too strong you will feel it in jerkily movements or a vibration.
If the power is adjusted too weak you will see it in creeping movements to the end point.
The motor power can be adjusted very easily as follows.

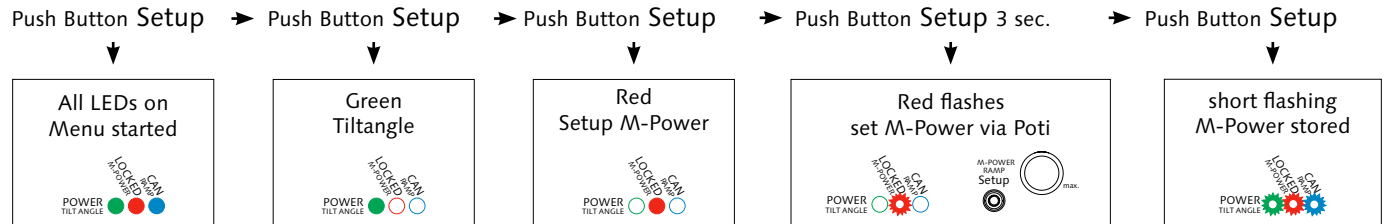
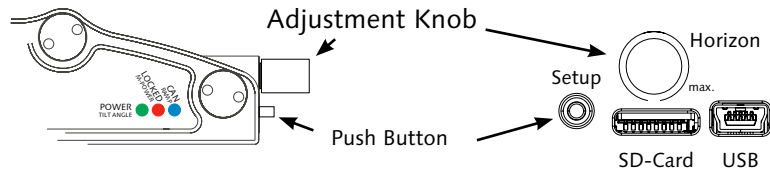

SET UP Ramp

Ramp is the speed when the frozen Horizon switches from the adjusted Tiltangle back to stabilization.
Ramp can be adjusted very easily as follows:

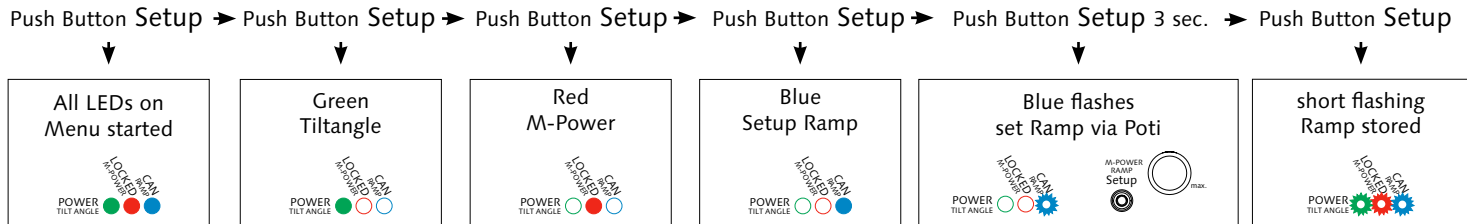
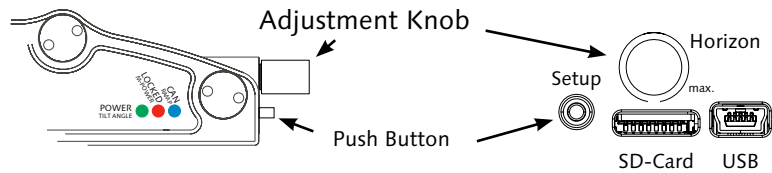

Trouble Shooting

Power LED flashes / Locked LED flashes 1/2/3/4 or 5 times switch off Wave and restart after about 5 sec.
If the error remains contact the manufacturer.

Power LED continuously flashes. Switch off Wave and restart after about 5 sec.

Wave stops in one direction far from the endstop or the Horizon can't be adjusted to the level.
The IMU has lost for some unknown reason the "zero position".

Preparation for recalibrating the "zero position" :

It is very Important that the power supply is designed for 3 Amp. at 14 Volt.

It is very Important that the Wave is placed on a solid and horizon oriented level surface.

The camera quicklockplate has to be placed in mechanical "zero position" and the Lok Pin is not be locked. Power supply is switched off.

Calibrating Set up "zero position"

- Push button "Set up" and hold, switch on power supply.
- Push button while the green and blue LED is permanent on.
- Release Push button the electronic "zero position" will now be adjusted.
- Red LED flashes fast, engage Lok Pin, red LED is permanent on.
- Wave determines now the mechanic "zero position" and stores it into the memory.
- Wait until green LED flashes slow and the red LED is permanent on.
- Setup is now finished switch off power supply and restart the Wave.

Warning! Disassembling the Wave will result in the unit having to be returned to the manufacturers for an electronic and mechanical rest.

Maintenance

The Wave is a maintenance-free sturdy electromechanical device. To guarantee a proper function you have to comply to the following points:

- Keep the eight roller guidance and the roller track clean!
- If the camera rocker hooks or the roller guidance get's loose please ask how to service and to adjust.

Isn't that easy?

Quicklockplate:

The locking mechanism should be treated/cleaned occasionally with a resinless oil (e.g. gun oil).

Placing a spacer in the locking mechanism:

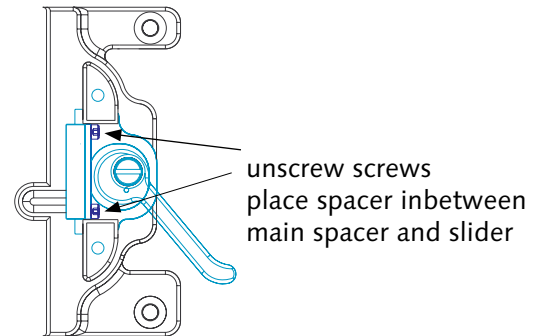
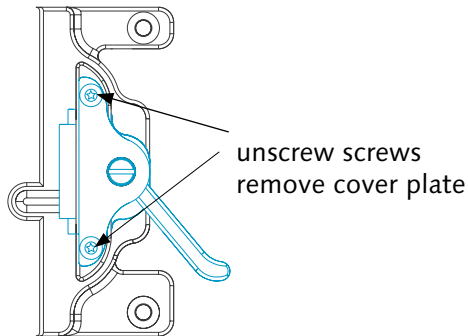

Technical Datas

Power source: DC 10 - 19 Volt

Power consumption: 500mA peak 2,5A

Horizont Stabilisation: +25° / -25°

Dovetailplates size: PRO / Steadicam Tiffen / Betz-Tools / MK-V

Weight: 1,45 Kg (3lb)

Overall size: 29 x 13 x 9 cm (11.4" x 5.1" x 3.5")

FCC Compliance:

Wave complies with part 15 of the FCC rules. Operation is subject to the following two conditions: (1) Wave may not cause harmful interference, and (2) Wave accepts any interference received, including interference that may cause undesired operation.

CE Compliance:

Wave complies with NF EN 50081-1 Emissions / NF EN 50081-1 Immunity. Operation is subject to the following conditions: Wave may not cause harmful interference, and Wave accepts any interference received, including interference that may cause undesired operation.

Any Question?

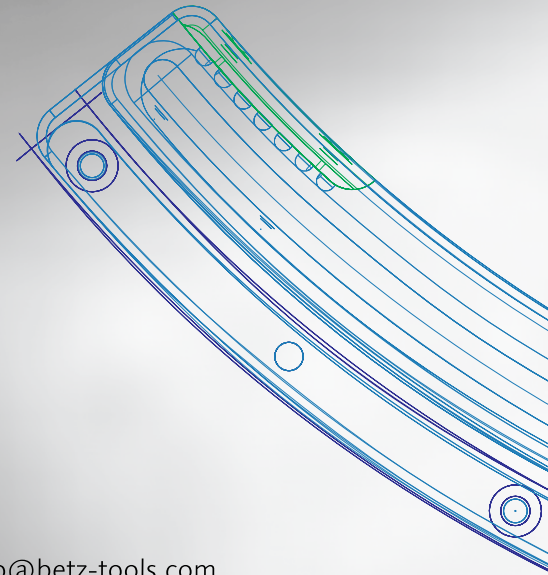

Munich Germany phone +49 (0) 89 65 11 32 20 mail info@betz-tools.com